

VIEW FROM UNDERNEATH

M6x25, FLAT & SPRING WASHERS
ALONG FRONT OF PLATE TO
BUMPER CROSSMEMBER

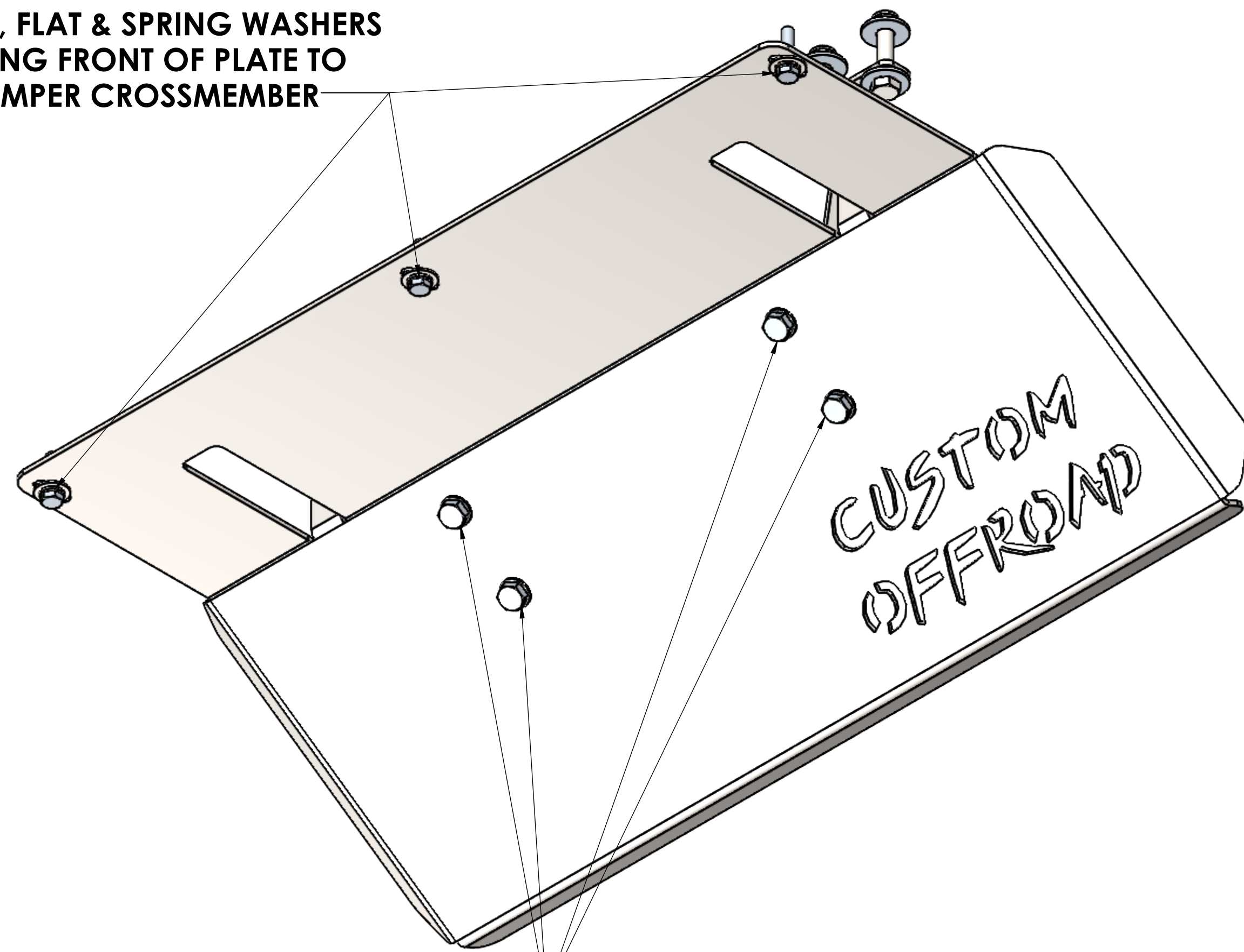

M8x30, SMALL FLAT & NYLOC NUTS
CONNECTING SUPPORT BRACKET TO
MAIN FRONT PLATE

FITTING PROCEDURE

1. ORIENTATE YOURSELF WITH EACH PLATE AND WHERE THEY WILL BE MOUNTED
2. LOCATE THE MOUNTING HOLES FOR THE BOLTS. THESE ARE LOCATED ON THE FRONT BUMPER CROSS MEMBER AND THE SWAY BAR MOUNTING TUBES
3. THE FRONT PLATE SUPPORT BRACKET CAN BE LOOSELY MOUNTED TO REAR HOLES CIRCLED IN RED IN THE PICTURE
4. LOOSELY BOLT MAIN FRONT PLATE TO THE THREE FRONT HOLES CIRCLED IN GREEN
5. LOOSELY BOLT CENTRE BOLTS INTO CENTRE HOLES CIRCLED IN BLUE
6. NUT AND BOLT SUPPORT BRACKET TO MAIN FRONT PLATE
7. LOOSELY BOLT SUMP PLATE IN PLACE AND FIT CROSS MEMBER CLAMP
8. ALIGN AND SQUARE UP ALL PLATES AND PROCEED TO TIGHTEN ALL BOLTS AND NUTS

VIEW FROM ABOVE

M8x40, LARGE FLAT WASHER & NYLOC
NUTYS CONNECTING SUPPORT
BRACKET TO VEHICLE

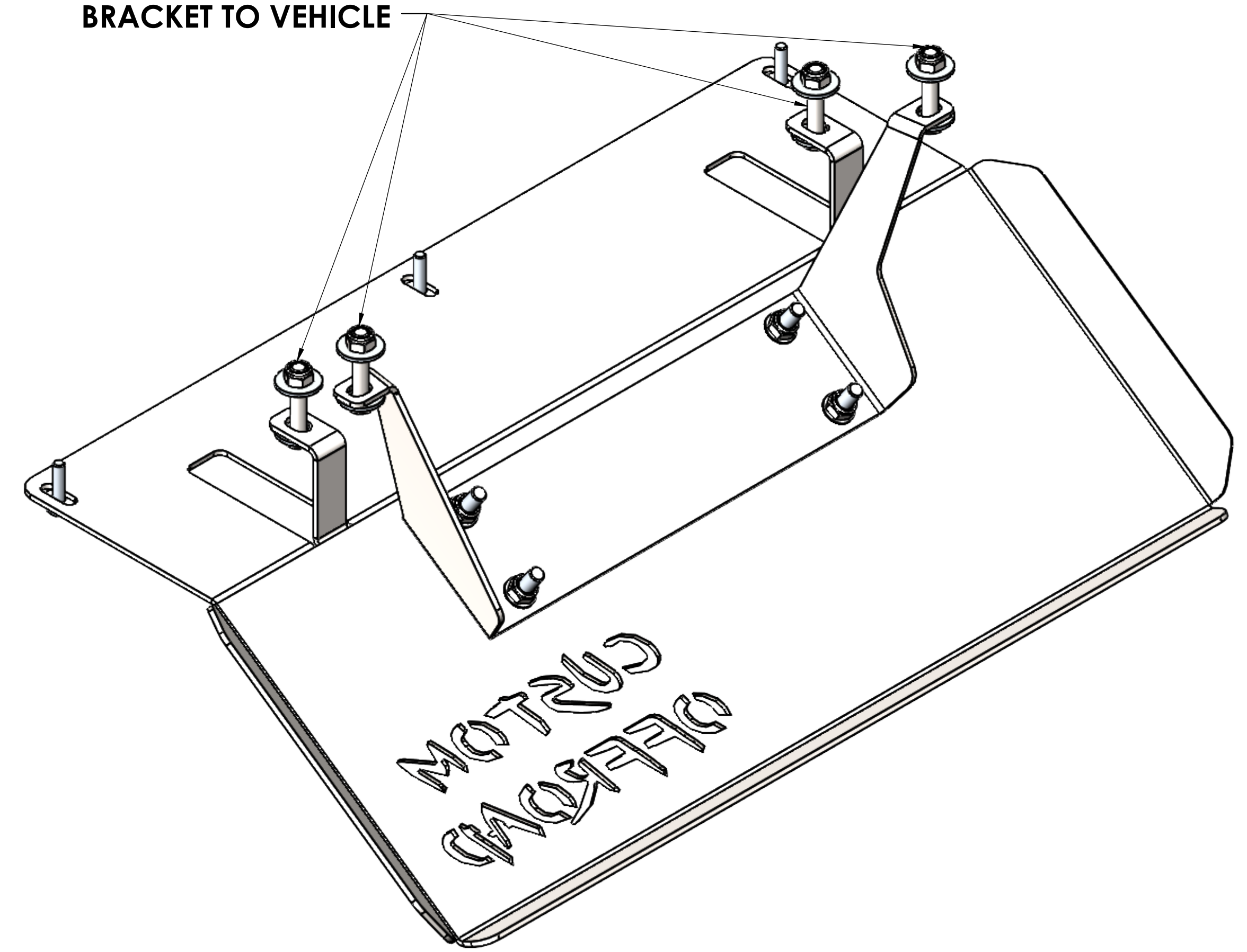

FRONT BOLT HOLES

CENTRE BOLT HOLES

REAR BOLT HOLES

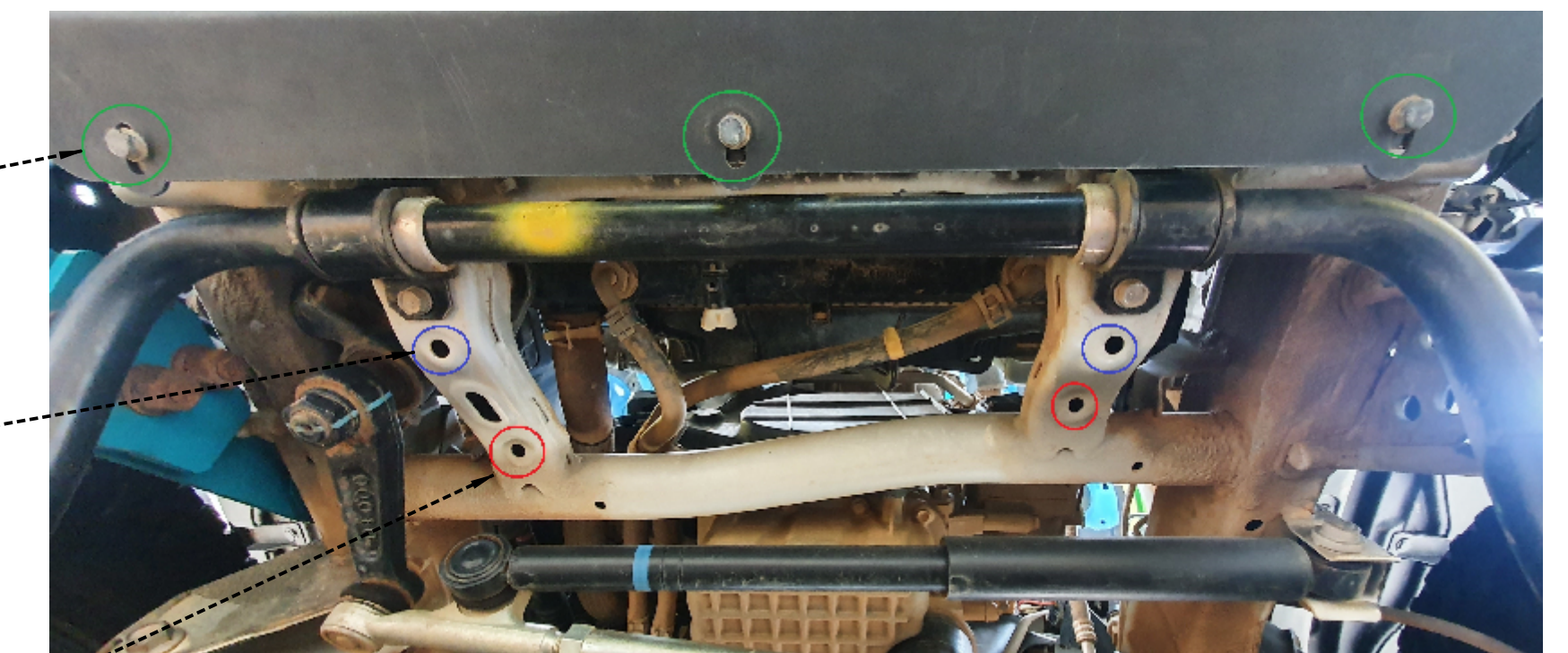

3mm PLATE WEIGHTS

FRONT PLATE	4.9 KG
SUPPORT BRACKET	1.0 KG
TOTAL	5.9 KG

REVISIONS A: 22/04/22 R. BELL ORIGINAL ISSUE	UNLESS OTHERWISE STATED UNTOLERANCED DIMENSIONS TO BE WITHIN THE LIMITS SHOWN					DRAWN RICHARD BELL	TITLE CUSTOM OFFROAD ACCESSORIES JIMMY (2018+) FRONT PLATE ASSEMBLY ASSEMBLY DETAILS	SIZE A1	DRAWING No. NUMBER COA-187		REV. D
	NOMINAL SIZE	UP TO 50	ABOVE 50 UP TO 150	ABOVE 150 UP TO 300	ABOVE 300 UP TO 1000	ABOVE 1000		APPROVED	CUSTOMER	PROJECT	
	MACHINING	± 0.1	± 0.2	± 0.3	± 0.5	± 1.0		DATE APPD	SCALE 1:2	CAD FILE	
	FABRICATION	± 0.5	± 0.5	± 0.5	± 1.0	± 2.0		DO NOT SCALE IF IN DOUBT ASK	COA-187(j)-Jimmy GY 2018 Front Plate ASY		
ASSEMBLIES	± 0.5	± 0.5	± 0.5	± 1.0	± 2.0		ALL DIMENSIONS IN MILLIMETRES UNLESS OTHERWISE SPECIFIED		This drawing and any information or descriptive matter set out herein are the confidential and copyright property of CUSTOM OFFROAD ACCESSORIES and must not be disclosed, copied or used for manufacturing/marketing or for any other purpose without the written permission.		

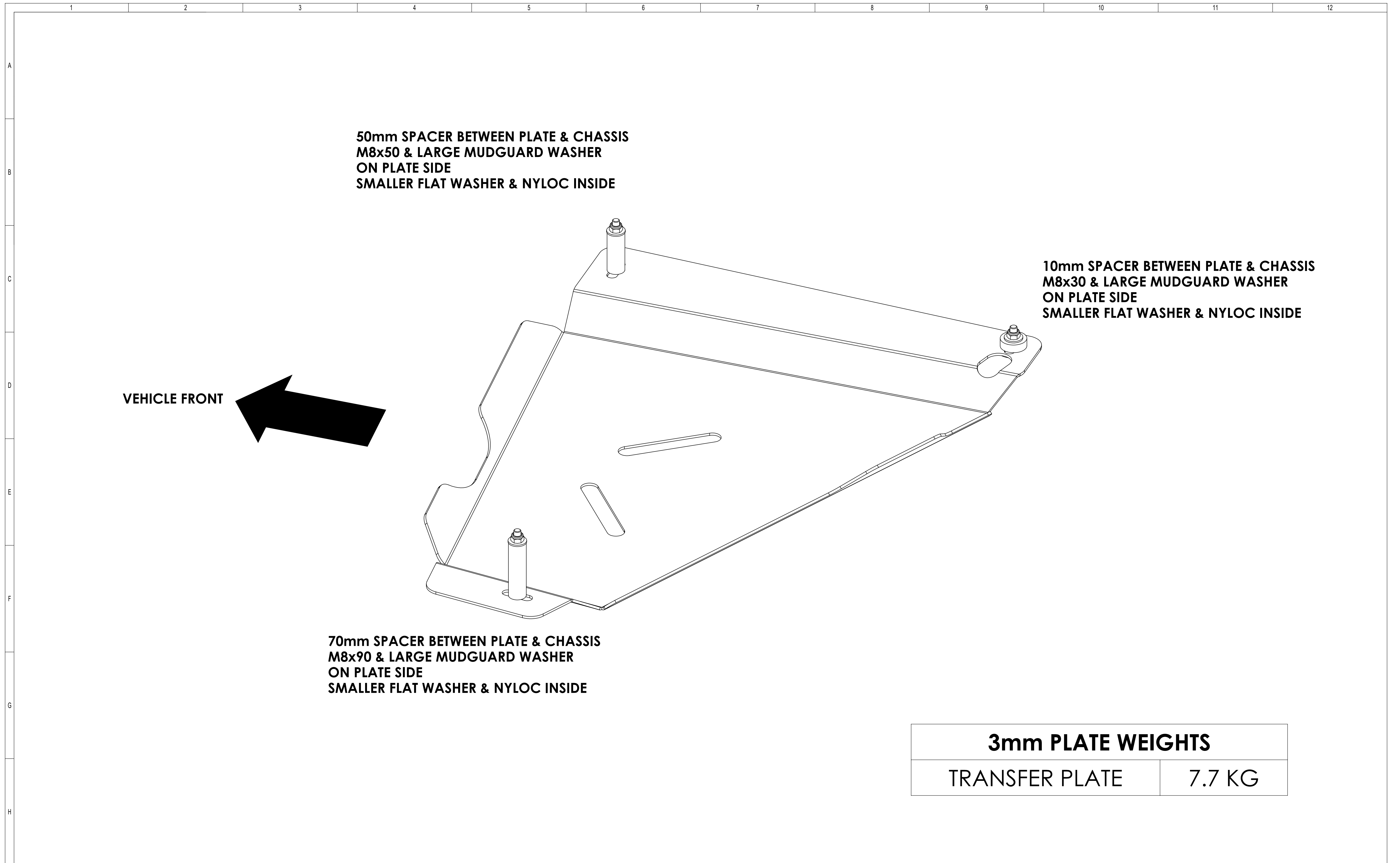

REVISIONS E: 05/08/22 R. BELL ISSUED AS PRODUCED	UNLESS OTHERWISE STATED UNTOLERANCED DIMENSIONS TO BE WITHIN THE LIMITS SHOWN					DRAWN	RICHARD BELL	ASSEMBLY AND BOLT DETAILS CUSTOM OFFROAD ACCESSORIES JIMNY (2018+) TRANSFER PLATE ASSEMBLY COMPONENT DETAILS	SIZE	DRAWING No.	
	NOMINAL SIZE	UP TO 50	ABOVE 50 UP TO 150	ABOVE 150 UP TO 300	ABOVE 300 UP TO 1000	CHECKED			A1	NUMBER	REV.
	MACHINING	± 0.1	± 0.2	± 0.3	± 0.5	± 1.0	APPROVED			COA-187-002	E
	FABRICATION	± 0.5	± 0.5	± 0.5	± 1.0	± 2.0	DATE APPD			CUSTOMER	
	ASSEMBLIES	± 0.5	± 0.5	± 0.5	± 1.0	± 2.0	SCALE		1:2	PROJECT	
							DO NOT SCALE IF IN DOUBT ASK	ALL DIMENSIONS IN MILLIMETRES UNLESS OTHERWISE SPECIFIED		<small>This drawing and any information or descriptive matter set out herein are the confidential and copyright property of CUSTOM OFFROAD ACCESSORIES and must not be disclosed, copied or used for manufacturing / marketing or for any other purpose without their written permission.</small>	