

**M8x30, WASHER & NYLOCS  
TO JOIN DELUXE TRANSMISSION  
HALVES TOGETHER (5 PLACES)**

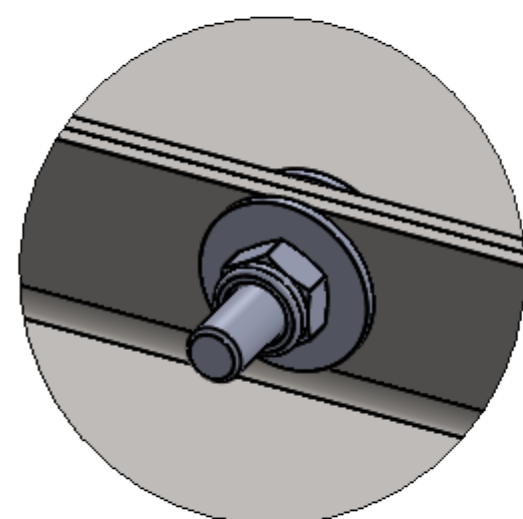

**DETAIL A  
SCALE 1 : 1**

**FITTING PROCEDURE**

1. ORIENTATE YOURSELF WITH EACH PLATE AND WHERE THEY WILL BE MOUNTED
2. START BY BOLTING THE TRANSFER PLATE IN FIRST, THE SUPPLIED NUTPLATE WILL NEED TO BE INSERTED INTO THE CROSS MEMBER FOR THE FRONT DRIVERS SIDE
3. LOOSELY BOLT THE MIDDLE SUMP PLATE IN PLACE, ONLY PUT ONE BOLT IN THE REAR AS THE TRANSMISSION PLATE WILL GO OVER THE TOP OF THE REAR FOLD
4. BOLT THE TWO HALVES OF THE DELUXE TRANSMISSION PLATE TOGETHER
5. SLIDE NUTPLATES INTO THE LEFT & RIGHT CHASSIS RAILS FOR THE WINGS OF THE TRANSMISSION PLATE
6. LOOSELY BOLT FRONT OF TRANSMISSION PLATE TO CENTRE CROSS MEMBER AND THEN PUT BOLTS THROUGH THE REAR CROSS MEMBERS, BOLT WINGS TO THE NUT PLATES IN THE CHASSIS RAILS
7. BOLT FRONT BRACE TO FRONT PLATE, IF PURCHASED, USING THE CENTRE HOLE WITH BOLT AND NUT (IF YOU HAVE A BULLBAR INFILL PLATE YOU MAY NOT BE ABLE TO USE THIS CENTRE BOLT)
8. LOOSELY BOLT FRONT PLATE & BRACE IN PLACE
9. ALIGN AND SQUARE UP ALL PLATES AND PROCEED TO TIGHTEN ALL BOLTS AND NUTS

**M10x40, LARGE FLAT WASHER,  
SPRING WASHER**

**M10x30, FLAT WASHERS  
& NYLOC NUT**

**M10x30, LARGE FLAT WASHER,  
SPRING WASHER (x2)**

**M6x60, FLAT WASHERS,  
NYLOC NUT**

**M10x30, LARGE FLAT WASHER,  
SPRING WASHER & NUTPLATE**

**M10x40, LARGE FLAT WASHER,  
SPRING WASHER**

**M8x60, FLAT WASHERS,  
NYLOC NUT (x2)**

**M10x30, FLAT WASHER,  
SPRING WASHER (x5)**

**M6x60, FLAT WASHERS,  
NYLOC NUT**

**M10x30, LARGE FLAT WASHER,  
SPRING WASHER & NUTPLATE**

**M10x30, LARGE FLAT WASHER,  
SPRING WASHER (x4)**

<b>PLATE WEIGHTS</b>	<b>3mm</b>	<b>4mm</b>
FRONT PLATE & BRACE	11.2 KG	13.9 KG
SUMP PLATE	6.6 KG	8.8 KG
TRANSMISSION	14.0 KG	18.7 KG
TRANSFER PLATE	4.3 KG	5.7 KG

REVISIONS A: 10/03/23 R. BELL ORIGINAL ISSUE	UNLESS OTHERWISE STATED UNTOLERANCED DIMENSIONS TO BE WITHIN THE LIMITS SHOWN				DRAWN	RICHARD BELL	ASSEMBLY AND BOLT DETAILS  CUSTOM OFFROAD ACCESSORIES NEXT-GEN FORD EVEREST 2022 - V6 WITH DELUXE TRANSMISSION COMPONENT DETAILS	SIZE	DRAWING No.		
	NOMINAL SIZE	UP TO 50	ABOVE 50 UP TO 150	ABOVE 150 UP TO 300	ABOVE 300 UP TO 1000	CHECKED			A1	NUMBER	REV.
	MACHINING	± 0.1	± 0.2	± 0.3	± 0.5	± 1.0		APPROVED		COA-210	A
	FABRICATION	± 0.5	± 0.5	± 0.5	± 1.0	± 2.0		DATE APPD		CUSTOMER	
	ASSEMBLIES	± 0.5	± 0.5	± 0.5	± 1.0	± 2.0		SCALE	1:3	PROJECT	
ALL DIMENSIONS IN MILLIMETRES UNLESS OTHERWISE SPECIFIED							DO NOT SCALE IF IN DOUBT ASK	CAD FILE COA-210-Ford Ranger 2022 Assembly Instructions			

This drawing and any information or descriptive matter set out herein are the confidential and copyright property of CUSTOM OFFROAD ACCESSORIES and must not be disclosed, copied or used for manufacturing / marketing or for any other purpose without their written permission.