

# VIEW FROM FRONT SIDE

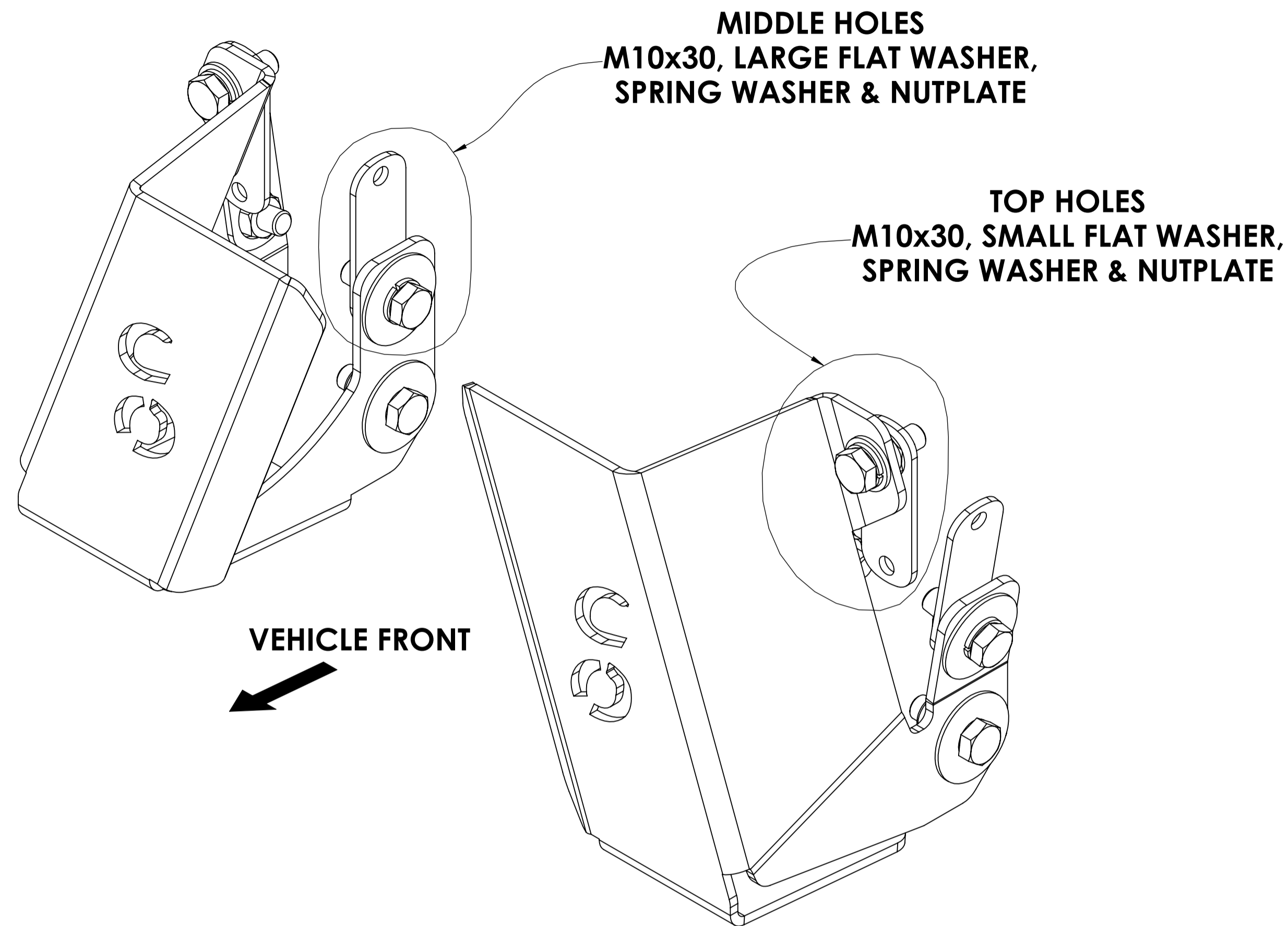

# VIEW FROM BACK SIDE

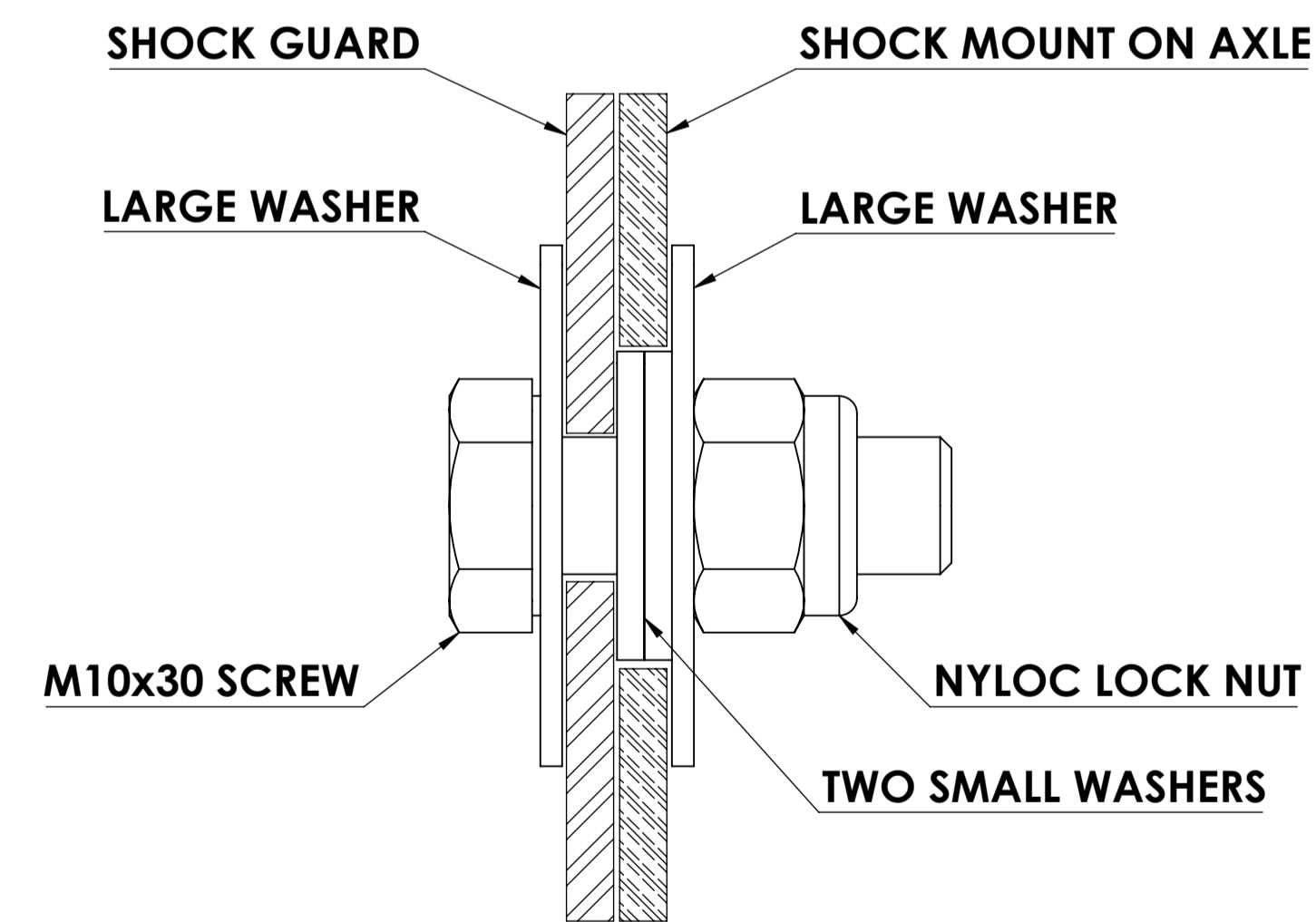
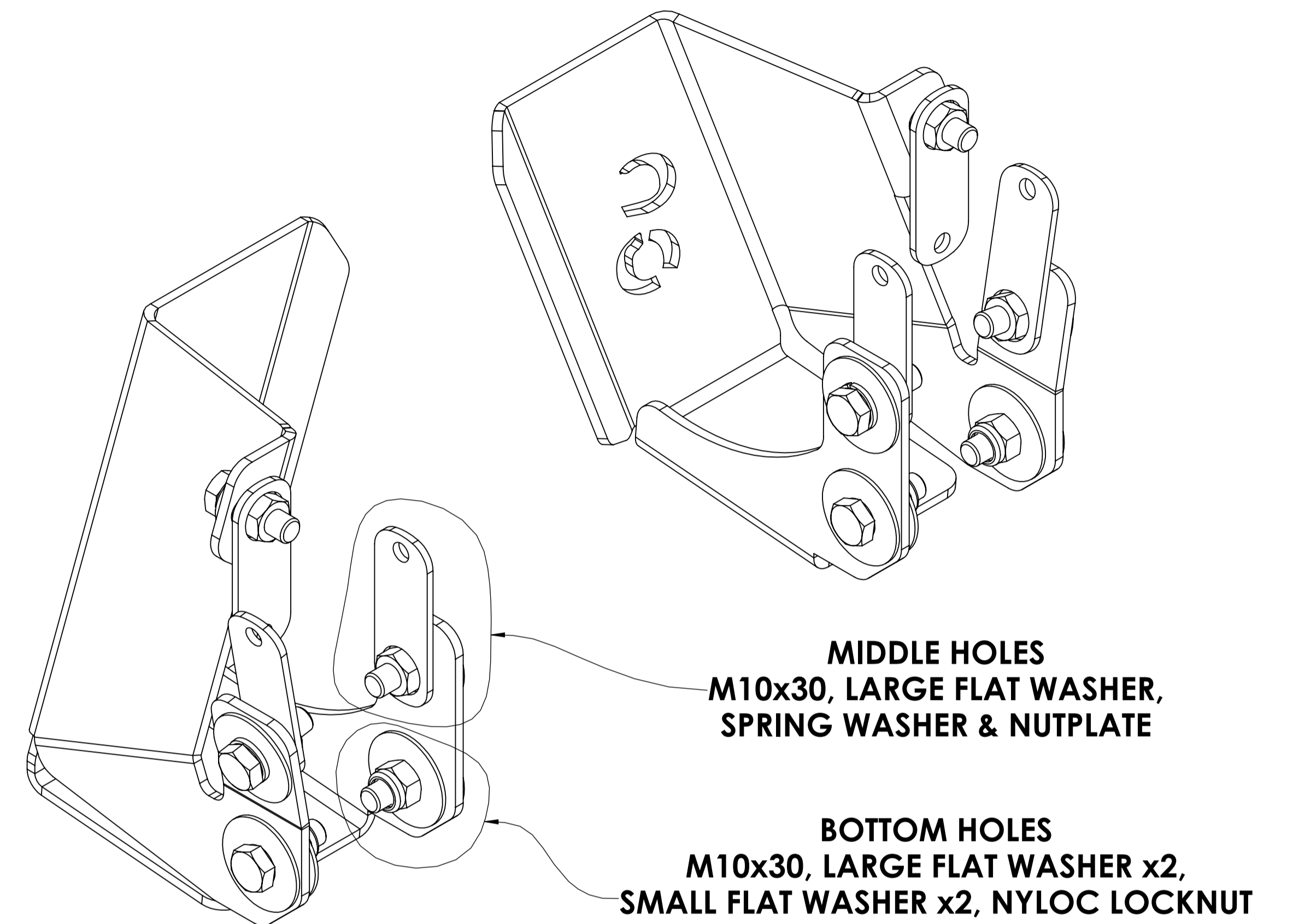

## BOTTOM HOLE ARRANGEMENT

## FITTING PROCEDURE

1. ORIENTATE YOURSELF WITH EACH GUARD AND WHERE THEY WILL BE MOUNTED
2. LOCATE THE MOUNTING HOLES FOR THE SCREWS BY TEST FITTING EACH GUARD
3. HOLDING A GUARD ON THE SHOCK MOUNT, LOOSELY FIT SCREW TO ONE OF THE BOTTOM HOLES TO ALLOW IT TO ROTATE AND MOVE UP & DOWN
4. SLIDE A NUT PLATE INSIDE THE SHOCK MOUNT & LOOSELY BOLT UP TOP HOLE
5. SLIDE TWO MORE NUT PLATES INSIDE SHOCK MOUNT & LOOSELY BOLT UP MIDDLE HOLES
6. FOR BOTTOM HOLES, USE TWO SMALL WASHERS IN THE LARGE HOLE IN THE SHOCK MOUNT AS PACKERS THEN LARGE WASHERS ON THE OUTSIDE WITH SCREW AND NYLOC LOCK NUT, AS PER THE BOTTOM HOLE ARRANGEMENT DIAGRAM
7. ALIGN AND SQUARE UP GUARDS AND PROCEED TO TIGHTEN ALL BOLTS AND NUTS

## PACKAGE CONTENTS

- LEFT HAND SHOCK GUARD x1
- RIGHT HAND SHOCK GUARD x1
- NUT PLATES x6
- M10x30 SCREW x10
- SMALL M10 WASHER x10
- LARGE M10 MUDGUARD WASHER x12
- M10 SPRING WASHER x6
- M10 NYLOC LOCK NUT x4

APPROX. WEIGHT - 4.2KG

REVISIONS A: 08/09/23 R. BELL ORIGINAL ISSUE	UNLESS OTHERWISE STATED UNTOLERANCED DIMENSIONS TO BE WITHIN THE LIMITS SHOWN				DRAWN	RICHARD BELL	ASSEMBLY AND BOLT DETAILS  CUSTOM OFFROAD ACCESSORIES TOYOTA LANDCRUISER 200 SERIES SHOCK GUARDS ASSEMBLY ASSEMBLY DETAILS	SIZE	DRAWING No.		
	NOMINAL SIZE	UP TO 50	ABOVE 50 UP TO 150	ABOVE 150 UP TO 300	ABOVE 300 UP TO 1000	CHECKED			A1	NUMBER	REV.
	MACHINING	± 0.1	± 0.2	± 0.3	± 0.5	± 1.0		APPROVED		COA-007	A
	FABRICATION	± 0.5	± 0.5	± 0.5	± 1.0	± 2.0		DATE APPD		CUSTOMER	
	ASSEMBLIES	± 0.5	± 0.5	± 0.5	± 1.0	± 2.0		SCALE	1:1.5	PROJECT	
ALL DIMENSIONS IN MILLIMETRES UNLESS OTHERWISE SPECIFIED							DO NOT SCALE IF IN DOUBT ASK	CAD FILE COA-007-Toyota Landcruiser 200 Series Shock Guards Assembly			

This drawing and any information or descriptive matter set out herein are the confidential and copyright property of CUSTOM OFFROAD ACCESSORIES and must not be disclosed, copied or used for manufacturing/marketing or for any other purpose without their written permission.